

1

2

3

4

A

A

B

B

C

C

D

D

E

E

F

F

SHEET FORMATS-1, FORMAT NO: F-8-DGN-10, Sht1 of 2 DT.01-11-05 Rew No-00-A4

REVISION					
ZONE	REV	FROM	TO	DATE	APPROVED

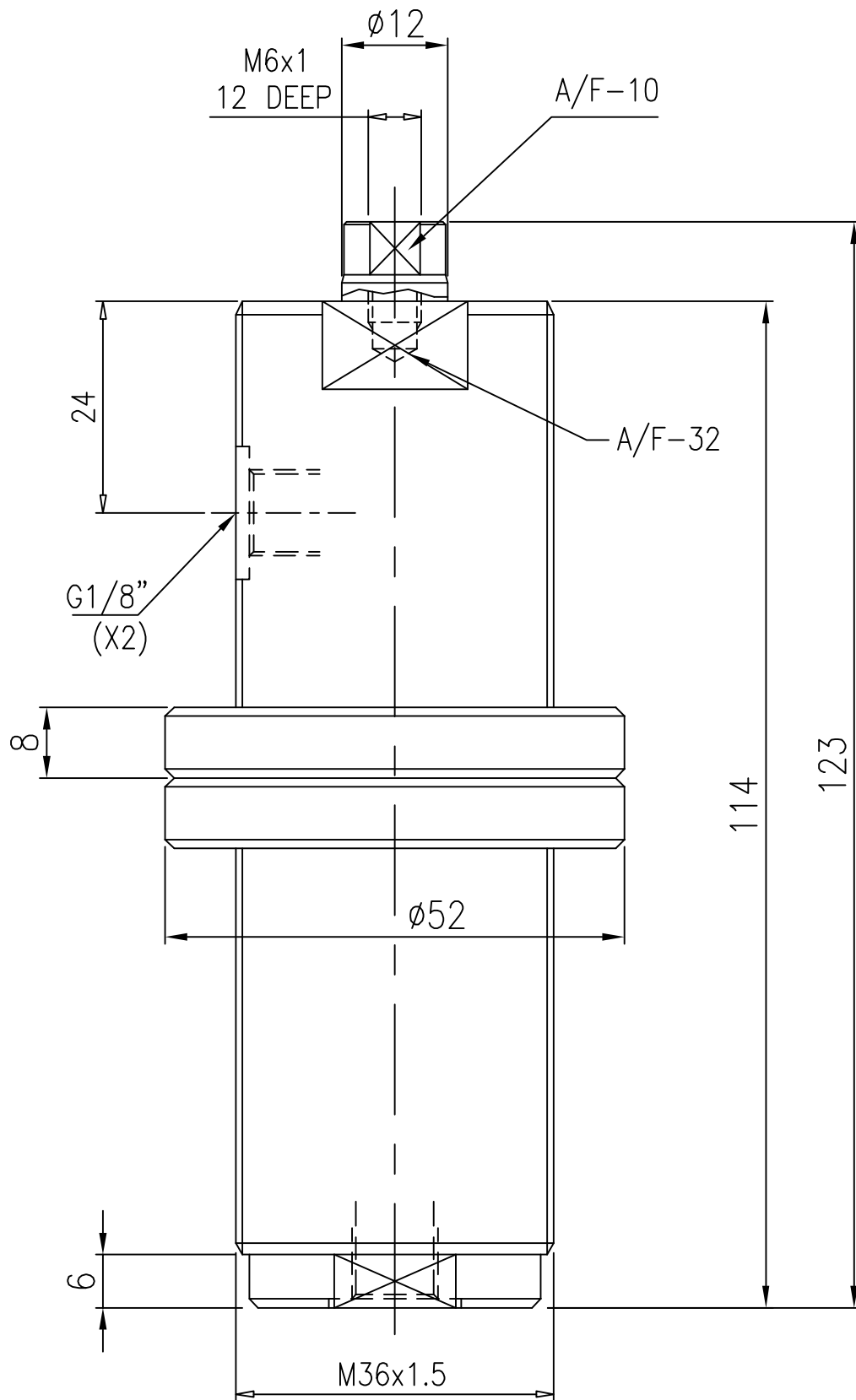

MAXIMUM OPEARATING PRESSURE	250 BAR
MINIMUM OPEARATING PRESSURE	10 BAR
STROKE	40 MM
DISPLACEMENT IN CC	8 cc
PISTON AREA	2 SQ.CM

1.0 GENERAL

- 1.1 ALL DIMENSIONS ARE IN MM.
- 1.2 DO NOT SCALE THE DRG. IF IN DOUBT ASK.

SURFACE FINISH	▽▽▽▽	▽▽▽	▽▽	▽	~								
Ra value μm	0.025	0.05	0.1	0.2	0.4	0.8	1.6	3.2	6.3	12.5	25	50	100

GENERAL TOLERANCES WHERE NOT SPECIFIED

LINEAR - LENGTH OR DIAMETER						ANGULAR-LENGTH IN MM OF SHORT SIDE OF ∠			
0.5-6	6-30	30-120	120-315	315-1000	1000-2000	UPTO 6	6-30	30-120	120-400
±0.1	±0.2	±0.3	±0.5	±0.8	±1.2	±1'	±30'	±20'	±10'

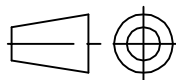

QUICLOC  
PVT LTD  
B'lore - 70

SCALE 1;1	TITLE MINI THREADED BODY CYLINDER D/A BORE-ø16XRODø-12XSTROKE-40 mm	MATERIAL XXX	SHEET NO 1 OF 1
DESIGN TIRUMAL 28-10-05	MACHINE TYPE	GROUP NO.	REPLACES
DRAWN TIRUMAL 14-11-05	CUSTOMER:	SUPERCEDED BY -	-
CHECKED		DRAWING NO. A52302	
APPROVED			

1

2

3

4