

1

2

3

4

A

A

B

B

C

C

D

D

E

E

F

F

SHEET FORMATS-1, FORMAT NO: F-8-DGN-10, Sht1 of 2 DT.01-11-05 Rew No-00-A4

| REVISION |     |      |    |      |          |
|----------|-----|------|----|------|----------|
| ZONE     | REV | FROM | TO | DATE | APPROVED |

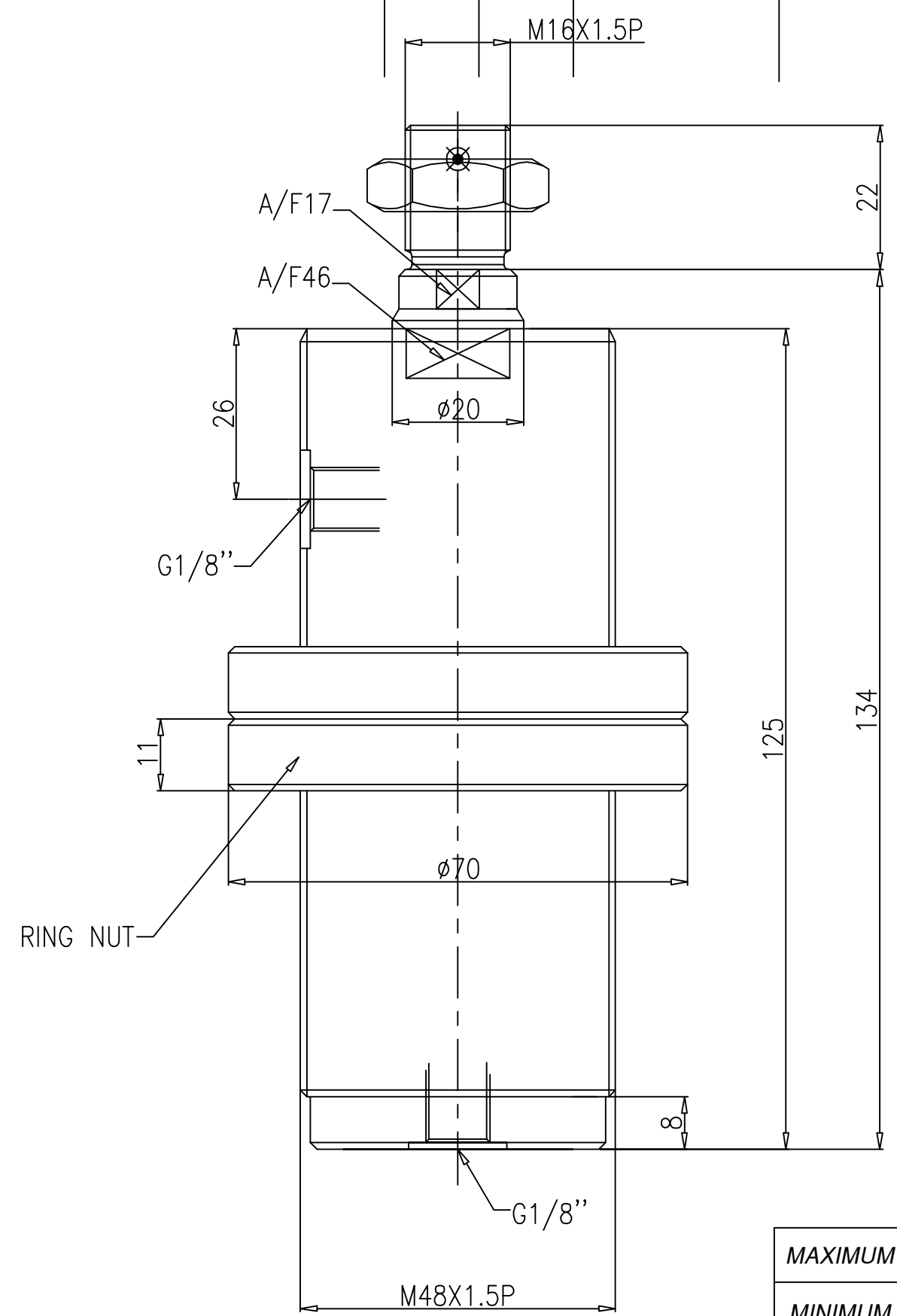

|                             |           |
|-----------------------------|-----------|
| MAXIMUM OPEARATING PRESSURE | 250 BAR   |
| MINIMUM OPEARATING PRESSURE | 10 BAR    |
| STROKE                      | 40 MM     |
| DISPLACEMENT IN CC          | 32 cc     |
| PISTON AREA                 | 8.0 SQ.CM |

- 1.0 GENERAL
- 1.1 ALL DIMENSIONS ARE IN MM.
  - 1.2 DO NOT SCALE THE DRG. IF IN DOUBT ASK.
  - 1.3 ROUND OF THE UNSPECIFIED EDGES.

| SURFACE FINISH |       |      |     |     |     |     |     |     |     |      |    |    |     |
|----------------|-------|------|-----|-----|-----|-----|-----|-----|-----|------|----|----|-----|
| Ra value μm    | 0.025 | 0.05 | 0.1 | 0.2 | 0.4 | 0.8 | 1.6 | 3.2 | 6.3 | 12.5 | 25 | 50 | 100 |

GENERAL TOLERANCES WHERE NOT SPECIFIED

| LINEAR - LENGTH OR DIAMETER |      |        |         |          |           | ANGULAR-LENGTH IN MM OF SHORT SIDE OF ∠ |      |        |         |
|-----------------------------|------|--------|---------|----------|-----------|---|------|--------|---------|
| 0.5-6                       | 6-30 | 30-120 | 120-315 | 315-1000 | 1000-2000 | UPTO 6                                  | 6-30 | 30-120 | 120-400 |
| ±0.1                        | ±0.2 | ±0.3   | ±0.5    | ±0.8     | ±1.2      | ±1'                                     | ±30' | ±20'   | ±10'    |

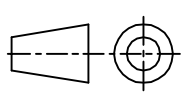

**QUICLOC  
PVT LTD  
B'lore - 70**

|                          |   |                              |                    |
|--------------------------|---|------------------------------|--------------------|
| SCALE<br><b>1;1</b>      | TITLE<br><b>MINI THREADED BODY CYLINDER D/A</b> | MATERIAL<br><b>XXX</b>       | SHEET NO<br>1 OF 1 |
| NAME<br><b>TIRUMAL</b>   | DATE<br><b>28-10-05</b>                         | GROUP NO.                    |                    |
| DESIGN<br><b>TIRUMAL</b> | DATE<br><b>14-11-05</b>                         | SUPERCEDED BY<br>-           | REPLACES<br>-      |
| CHECKED                  |   | DRAWING NO.<br><b>A52305</b> |                    |
| APPROVED                 |   |                              |                    |

1

2

3

4