

REVISION				
ZONE	REV	FROM	TO	DATE

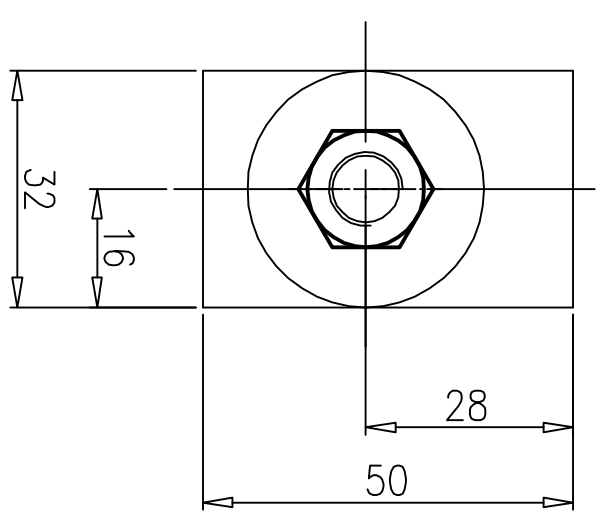
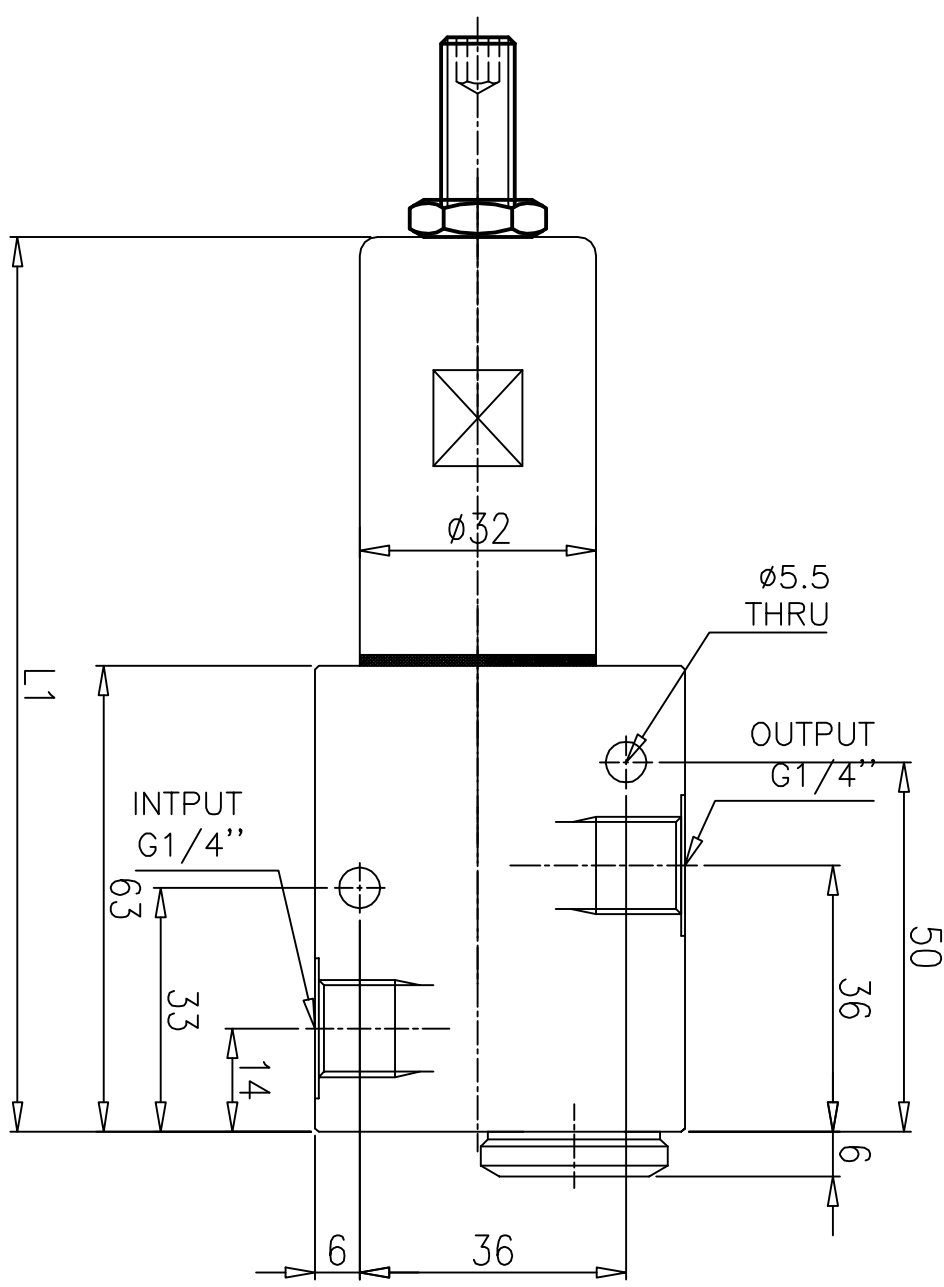

MODEL NO	V11101	V11102
Mex. flow allowed LPM	3	3
Nominal Bore	Nb 4	Nb 4
Port Size	G 1/4"	G 1/4"
Sq. Pressure range bar	10-80	60-150
L1	111	120

- 1.0 GENERAL
- 1.1 ALL DIMENSIONS ARE IN MM.
  - 1.2 DO NOT SCALE THE DRG.IF IN DOUBT ASK.
  - 1.3 SUBJECT TO CHANGE FOR IMPROVEMENT.

SURFACE FINISH		▽▽▽	▽▽▽	▽▽	▽	~
Ra value μm		0.025	0.05	0.1	0.2	0.4
LINEAR - LENGTH OR DIAMETER		0.5-6	6-30	30-120	120-315	315-1000
ANGULAR-LENGTH IN MM OF SHORT SIDE OF ∠		UP TO 6	6-30	30-120	120-400	400-1000
GENERAL TOLERANCES WHERE NOT SPECIFIED		±0.1	±0.2	±0.3	±0.5	±0.8
SCALE:		2:1				
TITLE		SEQUENCE VALVE				
MATERIAL:		-				
GROUP NO.:		-				
SUPERCEDED BY		-				
REPLACES		-				
DRAWING NO.:		-				
SHEET NO.:		1 OF: 1				

DESIGN	TIRUMAL	28-10-05	MACHINE TYPE	
DRAWN	TIRUMAL	11-01-06	CUSTOMER:	
CHECKED				
APPROVED				

1 2 3 4 5 6 7 8

F E D C B A